

COUPE A-A
ECHELLE 2 : 1

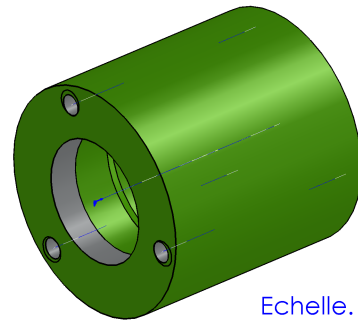
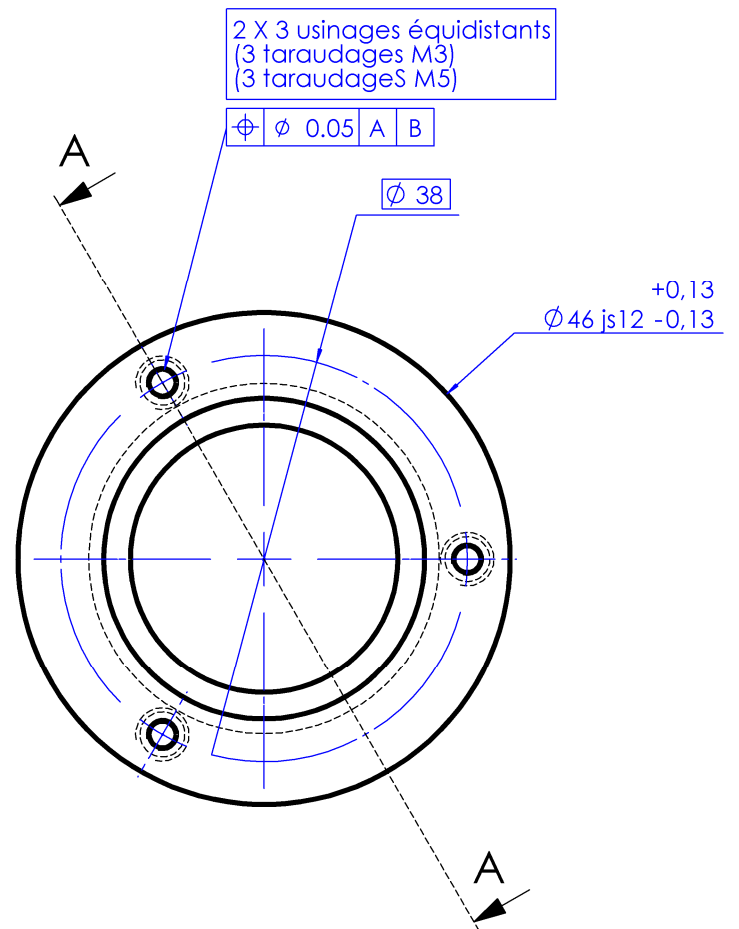

Echelle. 1:1

TOLERANCES GENERALES : ISO 2768 fK $\sqrt{\text{Ra } 3.2}$

4	1	Support roulement axe Z	2017A	4204
Rep	Nb	Désignation	Matière	Observation	Référence
Production Mécanique			LYCEE JEAN MONNET		
Format : A3		Année 2011		Parabole motorisée pour moteur STIRLING	
Ech. 2:1		Modification:			
Dessiné par: MPK		Modification:			